

**READ THESE INSTRUCTIONS COMPLETELY BEFORE STARTING WORK.  
IF YOU DON'T UNDERSTAND CALL 724-588-8600 FOR ASSISTANCE.**

## PROCEDURE FOR REPLACING ACCESS LADDER SPRING LOADED MECHANISM. KIT PART NO. 53463-01



**THIS KIT IS FOR USE ON WERNER LADDER CO.  
ACCESS LADDER MODELS ONLY  
ALL FOLDING MODELS**



**WARNING:**

1. Failure to comply with all instructions may result in serious injury and damage to the ladder.
2. Make sure this kit fits your ladder. Refer to the application chart on the outside of the kit's packaging. If you have any questions concerning the use of this kit on other Werner Ladder Co. products, call 724-588-8600 for assistance.
3. Before installing this kit, identify all kit components. If any components are missing or damaged, return the kit to place of purchase. Do not substitute any components.
4. Inspect the ladder before installing this kit. Repair or replace any damaged or missing ladder parts before using the ladder. Use only Werner Ladder Co. repair or replacement parts. If unable to repair, discard the ladder.

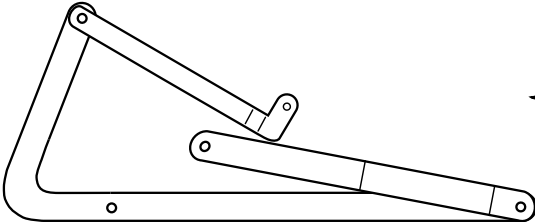
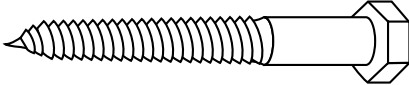
**TWO PEOPLE ARE REQUIRED FOR INSTALLATION OF THE REPLACEMENT MECHANISM.**

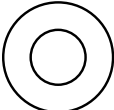
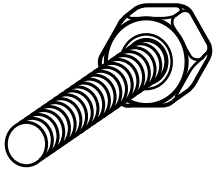
COMPONENTS IN KIT		TOOLS REQUIRED	
 <p>(2) ACCESS LADDER MECHANISMS (1 LEFT, 1 RIGHT)</p>		QUANTITY	DESCRIPTION
 <p>(2) 5/16" BY 3" LG. HEX HEAD LAG BOLTS</p>		(1)	DRILL WITH A 5/16" DRILL BIT
 <p>(2) LOCKNUTS</p>		(1)	CENTER PUNCH
 <p>(4) 5/16" FLAT WASHERS</p>		(1)	HAMMER
 <p>(2) 5/16" BY 1-1/2" LG. HEX HEAD BOLTS</p>		(1)	CHISEL
		(2)	HALF INCH WRENCHES
		(1)	13/64" DRILL BIT
			CONSTRUCTION ADHESIVE

### INSTRUCTIONS

**NOTE: TWO PEOPLE ARE NEEDED FOR THIS REPAIR PROCEDURE.**

- 1 One person needs to enter the overhead space. Once one person is in the overhead space the person below should close the access ladder to remove some of the tension in the spring. With the access ladder closed, the person in the overhead space should carefully remove the spring from the mechanism to be replaced.

**CAUTION: The spring is under tension and the ladder could open unexpectedly when the spring is removed!**

- 2 The person who is below the access ladder should slowly open the access ladder. The access ladder may open suddenly. Do not stand directly below the access ladder. Leave the sections of the access ladder folded. Do not stand on the access ladder.

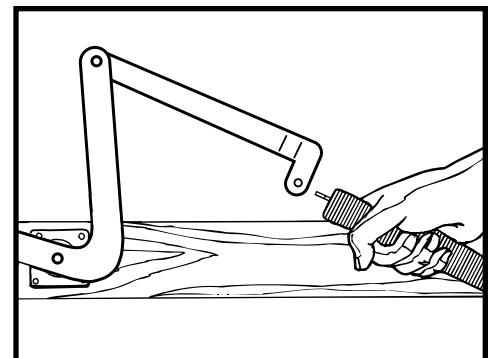

**INSTRUCTIONS CONTINUED ON BACK PAGE**

# INSTRUCTIONS

CONTINUED FROM FRONT PAGE

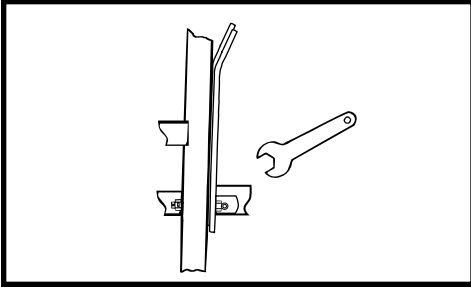

**3** **⚠** **WARNING:** Do not stand on the access ladder during this procedure! The person who performs this procedure must be standing on the floor or a stepladder. Remove the nut and carriage bolt that connects the mechanism to the rail of the ladder. Discard the old carriage bolt and lock nut.

**4** The person in the overhead space needs to perform this procedure. (A) Using the center punch, mark the center of the rivet that holds the mechanism to the frame. (B) Drill into the head of the rivet until the rivet head falls off. (C) If needed, tap the head of the rivet with the chisel and hammer keeping the chisel parallel to the mechanism.

**5** After the mechanisms have been removed the access ladder frame should be checked for squareness and the sides should be checked for straightness. If the frame is not square or the sides are bowed it is necessary to have those problems corrected before carrying out the installation of this kit. See the installation manual that came with the access ladder or contact the Werner Ladder Co. if you have any questions.

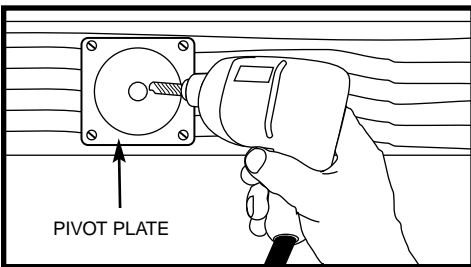

**6** After checking for squareness and straightness drill a 13/64" diameter pilot hole into the access ladder frame and the rafter using the pivot plate as a guide. Make sure the drill is

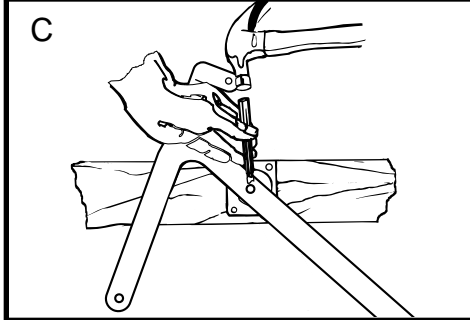
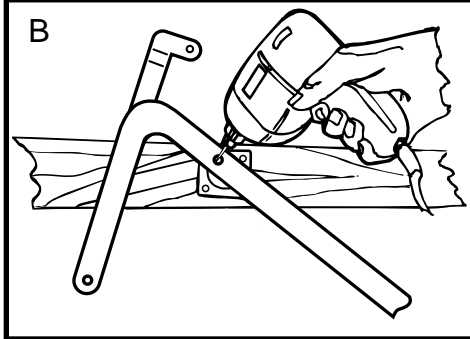
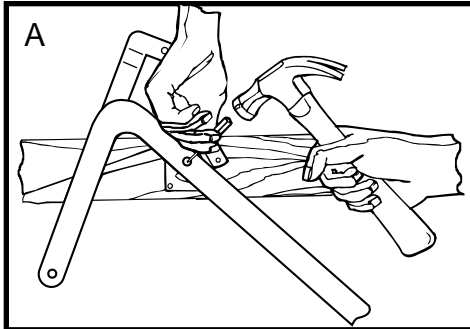

horizontal and perpendicular with the frame. It may be necessary to push the rivet out of the way so that the hole is clear to drill. The rivet will remain in the pivot plate and will not interfere with drilling or the function of the access ladder.

**7** The person in the overhead space needs to perform this procedure. Look for "U.S. PAT 5050706" followed by a "L" or "R" on the arm that the spring was attached to. Make sure the new mechanism has the same identifying marks. Place the washer on the 5/16" lag bolt. Coat the threads of the lag bolt with Construction Adhesive, (Example: Liquid Nails®). Then insert the bolt through the mechanism, pivot point, and into the frame.

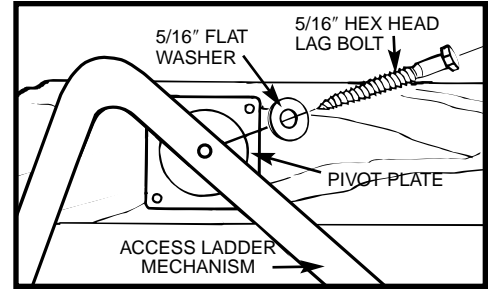

The lag bolt must be perpendicular to the frame. Tighten the lag bolt until the mechanism is firmly against the pivot plate. The mechanism should be easily moved by hand without any gap between the mechanism and pivot plate.

**8** The person standing on the floor needs to perform this procedure. Attach the mechanism to the rail with the new hex head bolt, lock nut, and washer. The head of the bolt should be against the mechanism and the washer should be against the inside of the rail. Tighten the bolt until the mechanism is firmly against the angle bracket and the washer is slightly pulled into the wood side rail.

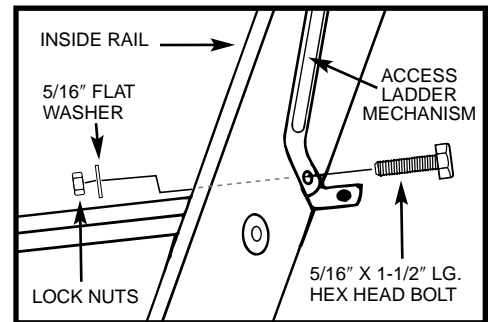

**9** Close the access ladder so that the person in the overhead space can attach the spring to the new mechanism.

**10** Open and close the access ladder several times to see if the access ladder operates properly. Check the lag bolt and the carriage bolt to see if they are tight. Adjust the bolts so that the ladder opens and closes easily.

**11** Repeat this procedure for the other side if required.

**NOTE:** Never force the access ladder door closed. Forcing the door closed can damage the mechanism. If the access ladder door will not close, pull the mechanism towards the front of the ladder and try to close the access ladder again.

\* Liquid Nails is a registered trademark of the Glidden Co.



WERNER LADDER CO., 93 WERNER ROAD, GREENVILLE, PA 16125-9499  
PHONE (724) 588-8600