



INSTALLATION GUIDE

Pro Tech

Read instructions carefully and completely before beginning installation.









WARNING

- *This stairway is for residential use only.*
- *Maximum capacity is 350 lbs.*
- *Two helpers will be needed to lift the stair to the ceiling rough opening.*
- *Installer should be experienced in the construction or modification of structural framing supports. Improper installation can result in stair collapse and bodily injury.*
- *Determine location of electrical lines or plumbing before cutting ceiling.*

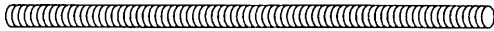
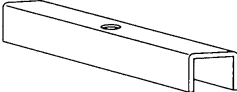
TOOLS AND MATERIALS REQUIRED

Drill, tape measure, 1/4" wood drill bit, hammer, hacksaw, crescent wrench, wood shims, nails for support boards, 1 X 4 support boards, ladder, lumber with same dimensions as joists, keyhole saw or utility knife to cut ceiling material.

PARTS INCLUDED

- | | |
|-----------------------|--|
| (4) 3/8" Threaded Rod |  |
| (4) Joist Hanger |  |
| (8) 3/8" Hex Nut |  |
| (10) 3" Lag Screw |  |
| (2) 1/2" Wood Screws |  |
| (1) Door Hook |  |
| (1) Wood Dowel |  |

BEFORE INSTALLATION

- Confirm that this attic stair and its installation meet all applicable building codes.
- Inspect stair unit for any damage.
- Check that all parts from Page 1 are included in carton.

1 LOCATING STAIR

1. Measure ceiling height (finished floor to finished ceiling) and verify that your unit conforms to your ceiling height in TABLE A.
2. Determine whether the chosen location allows sufficient “projection” and “landing space” for your unit. See TABLE A below and Figure 1 & 2 on next page.

MODEL #	COLOR	ROUGH OPENING SIZE	FRAME DIMENSIONS	TREAD WIDTH	FLOOR TO CEILING HEIGHT RANGE	PROJECTION	LANDING SPACE
PT2351	WHITE	23 1/2" x 51 1/4"	23 1/4" x 50 3/4"	14"	8' to 10'	16"	46"

TABLE A

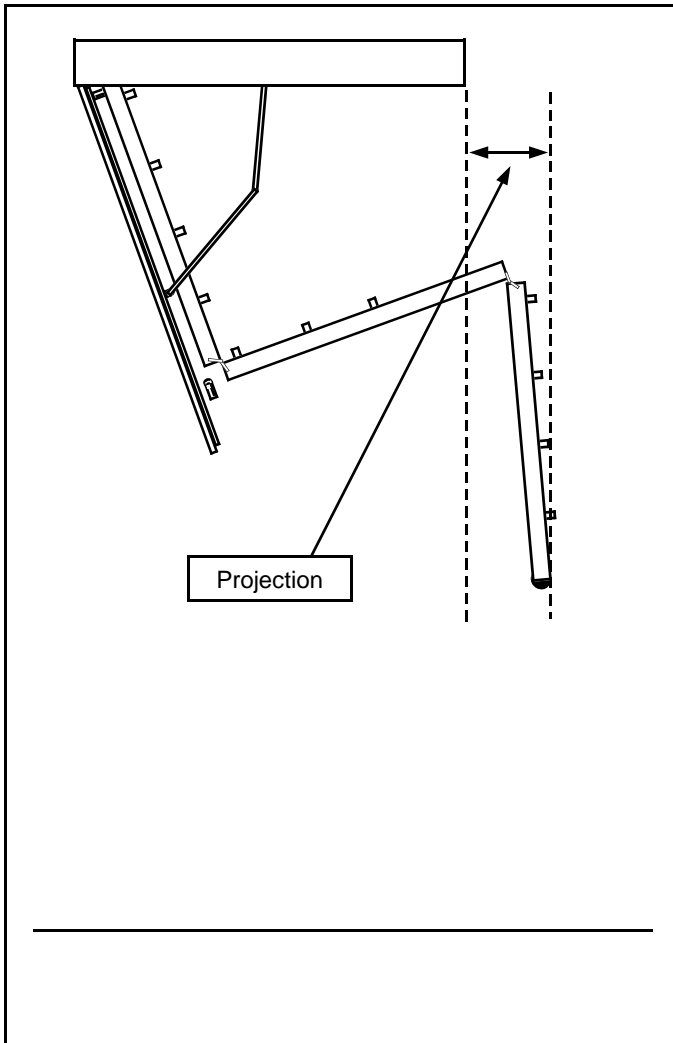

Figure 1

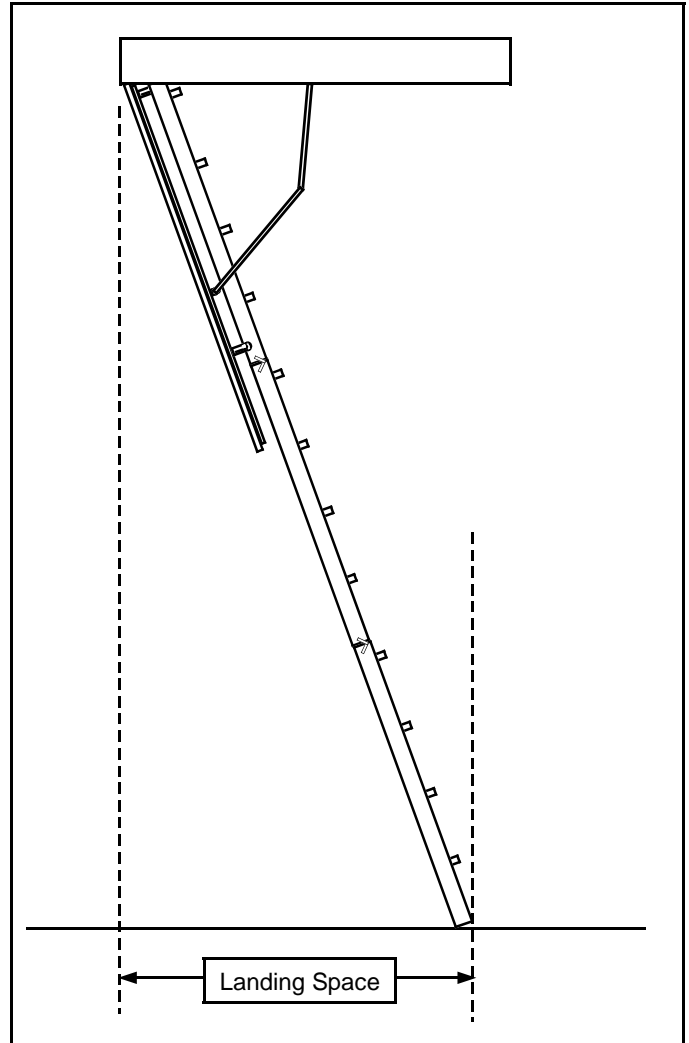

Figure 2

PREPARING THE OPENING

1. Mark out the rough opening size for your unit according to TABLE A. *Note that the finished metal trim extends about 2" beyond the rough opening when the unit is installed (Figure 3). Allow clearance for this on all four sides.*
2. Cut the rough opening through the ceiling material.

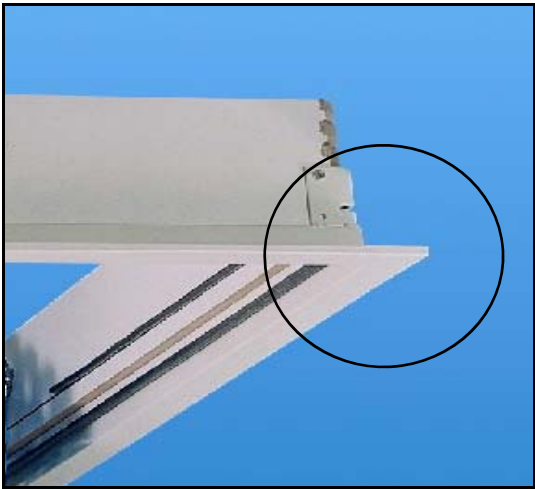

Figure 3

FRAMING THE OPENING

Most attic stairs will be installed parallel to the ceiling joists (Figure 4). In cases where they are installed perpendicular to joists (Figure 5), some joists will need to be cut and tied-in to other joists with 2" x 6" or 2" x 8" "headers". These headers will form the box frame into which the stair will be secured.



WARNING

- ***Before cutting any joists, watch out for electrical wiring.***
- ***If your attic is constructed using trusses, DO NOT CUT CEILING JOISTS WITHOUT CONSULTING AN ENGINEER AND OBTAINING APPROVAL.***
- ***Because of the weight of the Rainbow Attic Stair it is highly recommended that DOUBLE HEADERS and JOIST BRACES be used for greater strength and safety.***

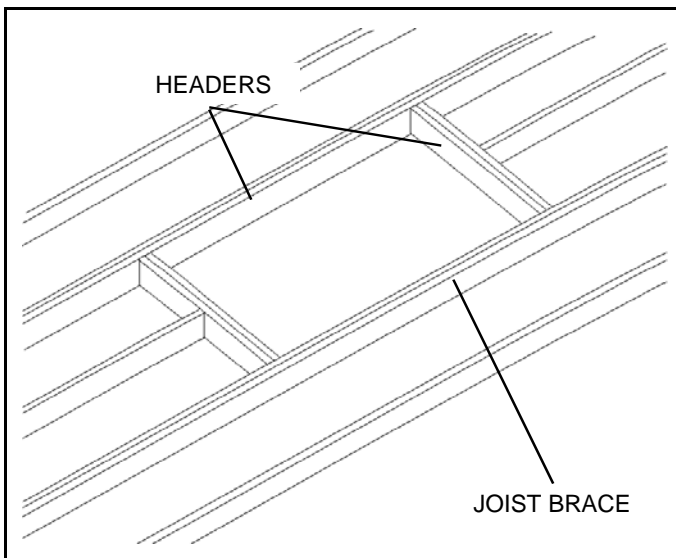

Figure 4

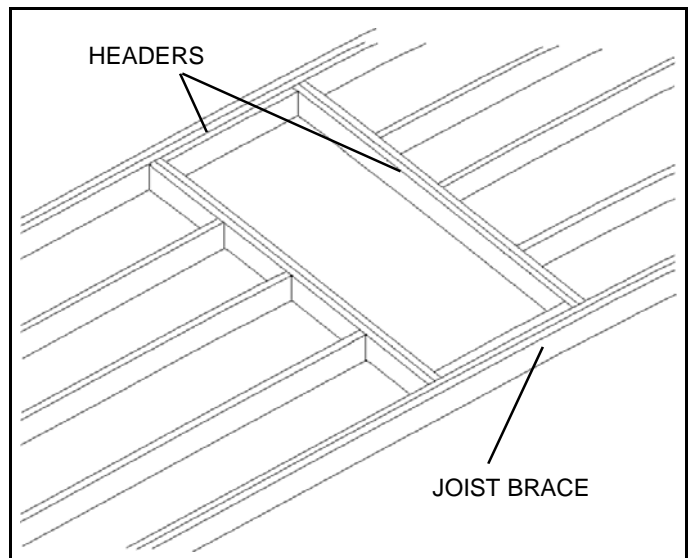

Figure 5

PREPARING THE STAIR

Insert hex nuts provided into slot in metal frame corner and insert threaded rod into channel. Thread rod into nut as far as possible. Repeat process for all corners. Figure 6.

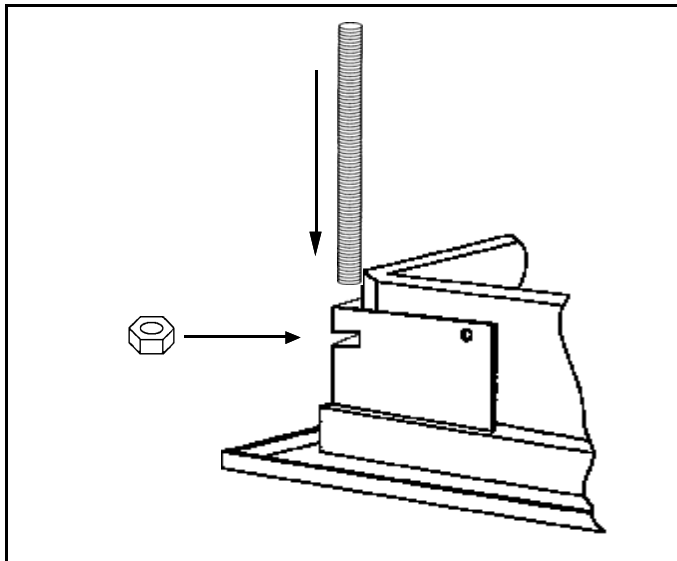

Figure 6

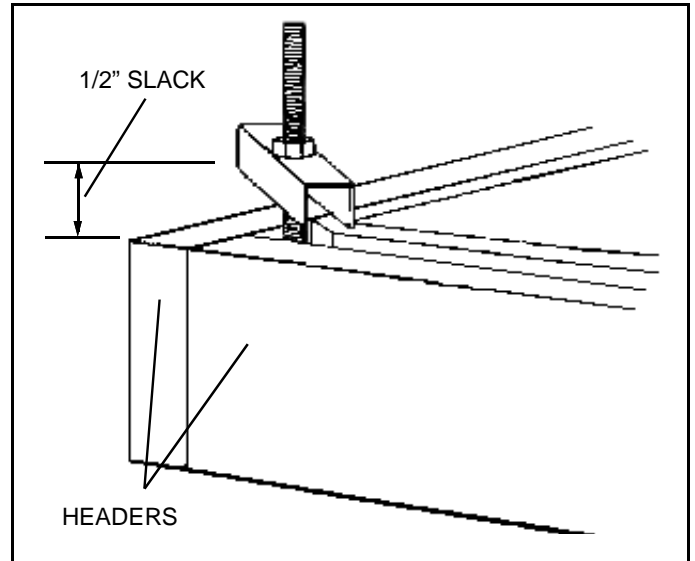

Figure 7



WARNING

- **Be sure that there is adequate light in the attic since the stair will block any light from the room below when raised into place.**
- **Make sure door is closed and latch is engaged**

INSTALLING THE STAIR

1. Person in attic should have ready the four joist hangers and hex nuts.
2. Have two additional helpers below lift the stair straight up into the framed opening until the tops of the threaded rods clear the top of the frame opening headers.
3. Starting at one end, slide a joist hanger onto the threaded rod and thread nut down until there is only about 1/2" slack. **Do not tighten fully.** Turn joist hanger at a 45 degree angle to span the frame corner. Figure 7. Repeat the process until all hangers are installed. With hangers holding stair in place, helpers can let go.
4. Square stair to frame. Try to maintain an even gap all around between stair and headers.
5. Tighten nuts in stages all around being careful not to over-tighten.
6. Attach door opening hook to wood dowel using (2) 1/2" wood screws.
7. Door can now be opened but **DO NOT EXTEND OR STAND ON STAIR YET.**

Note: Rainbow "ProTech" stairs are designed to be installed with both steel joist hangers and lag screws. Do not install with lag screws alone.

8 LAG SCREWING THE FRAME

1. Mark location of lag screws. Pre-drill pilot holes, shim and screw stair frame to headers using three lag screws on each long side and two on each end. Figure 8.

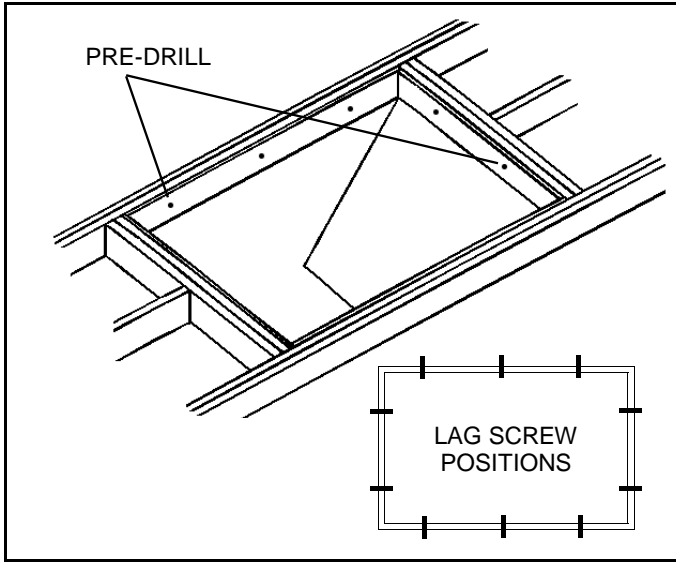

Figure 8

7 HEIGHT ADJUSTMENT

1. Unfold all sections as shown in Figure 9.
2. Using a straight edge, measure the distance from Point A to Point B using the back side of center section as a guide.
3. Slide rubber bumper off stair and transfer measurement to the back side of the section, Figure 10.

Note: Measure and cut each leg separately since there may be a variation in the floor level.

4. Make 90 degree cut and replace rubber bumper.

Note: If cut line is within 1" of bottom of tread, make cut just ABOVE tread. The set screw as shown in Figure 11 will be adjusted to correct this.

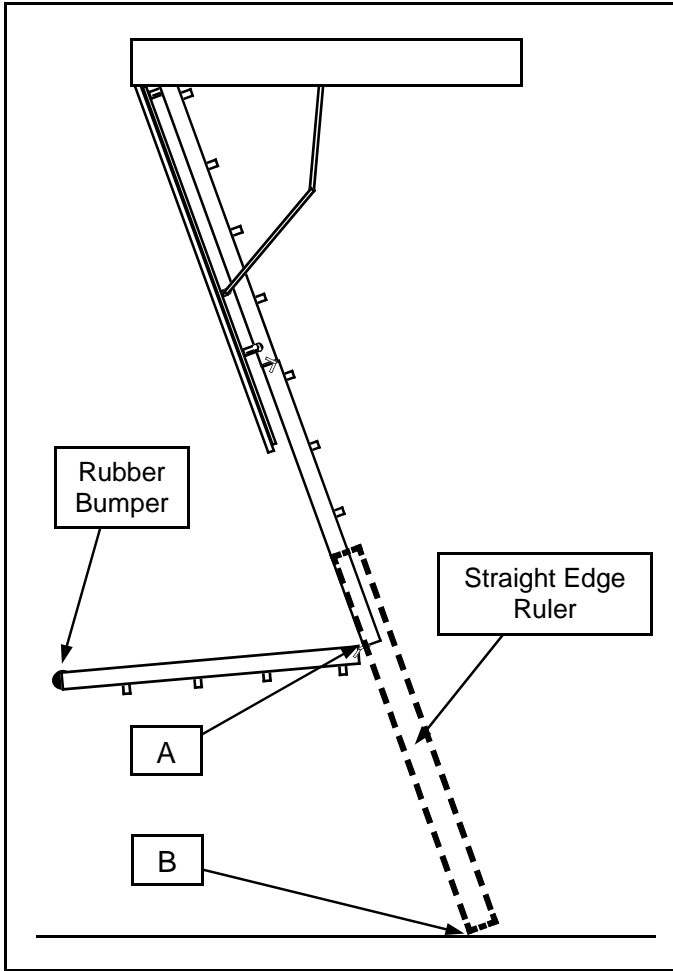

Figure 9

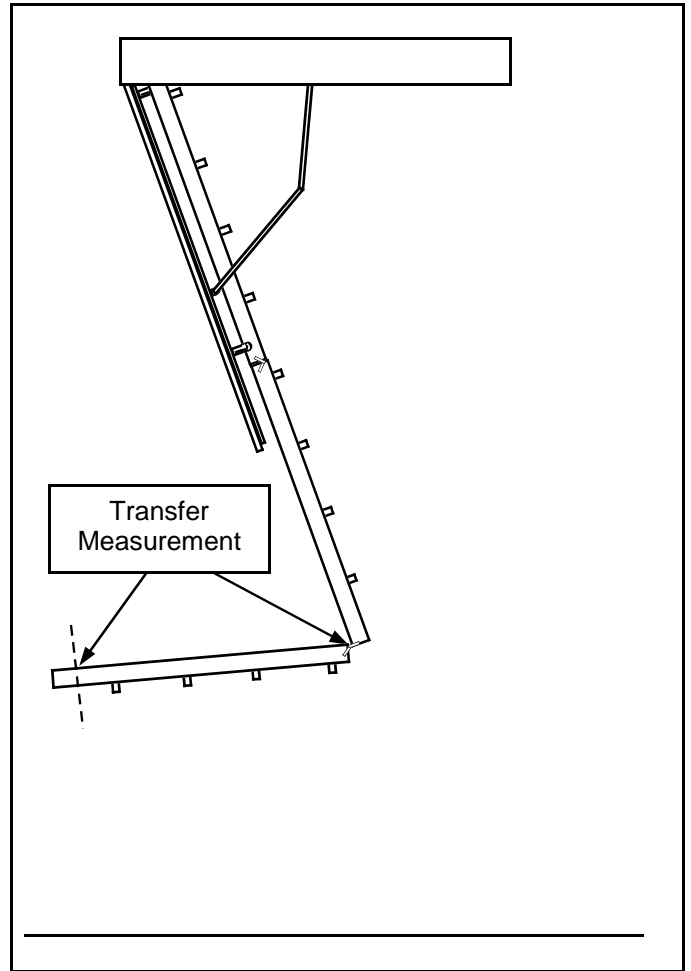

Figure 10

FINAL ADJUSTMENT

1. Extend all sections to a straight position. Stair should now rest firmly on floor with no gaps where sections come together.
2. If there are gaps or if the stair does not reach the ground, turn the set screw (Figure 11) clockwise to lower stair, or counter-clockwise to raise it.

Note: Be sure to adjust both sides equally, and in small increments until stair rests properly on floor and there are no visible gaps between sections.

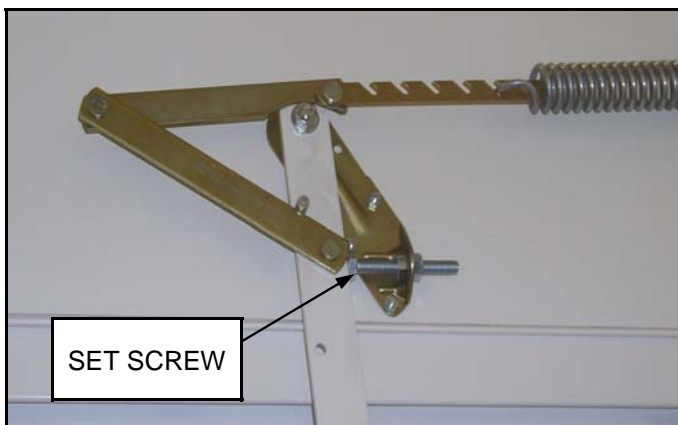

Figure 11

Congratulations!

You are now ready to begin using your Rainbow Attic Stair. As with any product, be sure to follow instructions for safe, efficient and trouble-free operation for years to come.

****** Children should never be allowed to operate or climb any attic stair. ******

LIMITED WARRANTY

SP Partners, LLC warrants that the unit will be free from any defects in material and workmanship for two years from purchase date provided that the stair is installed in compliance with the preceding instructions and operated and maintained in accordance with these instructions and applicable warnings.

This warranty specifically excludes any and all non-defect damage, any and all damage, injuries and losses arising from improper installation of this product, unreasonable use to include exceeding the specified weight limitations, and any and all labor charges incurred for removing or reinstalling a repaired stair unit or any of its components.

During the warranty period stated, should the stair unit or any of its components exhibit a manufacturing defect please first call SP Partners, LLC at 877-369-6996 before dismantling the product in order to determine the extent of the defect and what course of action needs to be taken to correct the problem. A proof of purchase will be required in all cases.

ADDITIONAL EXCLUSIONS

SP Partners, LLC's above-stated express limited warranty is being made in lieu of all implied warranties of any kind, including those as provided by the Uniform Commercial Code for merchantability of the product and for fitness of the product for a particular purpose. All such implied warranties, including those of merchantability and/or fitness for a particular purpose, are excluded and disclaimed. Furthermore, all claims for consequential damages and for incidental damages that may arise from a breach of the above-mentioned express warranty are also excluded. In no event shall SP Partners, LLC be liable for any breach of warranty and/or for any negligence and/or for any strict liability which would exceed in damage amount the cost of the stair unit.

No representative or person is authorized to assume for SP Partners, LLC, any responsibility which would be either an alternative to or in addition to the express product warranty as stated above. This warranty gives you certain specific legal rights as were set forth above and any other rights that may vary from state to state. If any portion of this express warranty is deemed to be unenforceable at any time hereafter, any such provision shall be severed from this agreement, but all other terms, conditions and provisions shall remain in full force and effect.

SP Partners, LLC

Tel: 877-369-6996

Website: www.RainbowAtticStair.com

Email: info@RainbowAtticStair.com